

RAD-Gigastar 2

Active Tap / Gateway / Media Converter / Vehicle Interface, & Data Logger

The RAD-Gigastar 2 is the most versatile Automotive Ethernet development tool available. It is an Automotive Ethernet Active Tap and Media Converter that integrates 100/1000BASE-T, 100/1000BASE-T1, 10BASE-T1S, CAN FD, and LIN.



All networks run simultaneously and are time stamped with 25 ns precision. Traffic can then be logged to internal non-volatile memory, streamed to another data logger, or streamed to a host PC running Vehicle Spy, Wireshark, or software written with Intrepid's Open Source API.

The RAD-Gigastar 2 can also internally bridge any of its network ports. This is useful to serve as a media converter between Automotive Ethernet and a 100/1000BASE-T device such as a PC. It can also be configured as a powerful gateway between any of its Ethernet, CAN, or LIN ports.

Features:

- gPTP Time synchronization for integration with Autonomous Logger Systems.
- Stand Alone Logging
 - Internal NVM with logging up to 480Mbps
 - 25 ns Real Time Clock (RTC) with battery backup
 - Automatic power management wake up modes
- Flexible Host PC Interfaces
 - Isolated USB 3.1 connection
 - 1G SFP Port (1000BASE-T or other Physical Layers)
- 5.5 - 60V power range, compatible with in-vehicle power.
- Push buttons to control device modes
- Status LEDs
 - Network status and activity
 - T1 and T1S SQI indication
 - T1S PLCA Status

Compatible Software

- Compatibility with Vehicle Spy and Wireshark
- Open-Source Intrepid API for direct network access in Windows or Linux applications.

Applications:

- ECU-level and system-level automated testing
- Automotive Ethernet network monitoring
- Network simulation / Restbus simulation
- Flexible Media conversion between all Ethernet interfaces
- Automotive Ethernet to CAN FD Gateways
- ECU reflashing over Automotive Ethernet or CAN FD
- Standalone or CMP streaming data logging applications



RAD-Gigastar 2

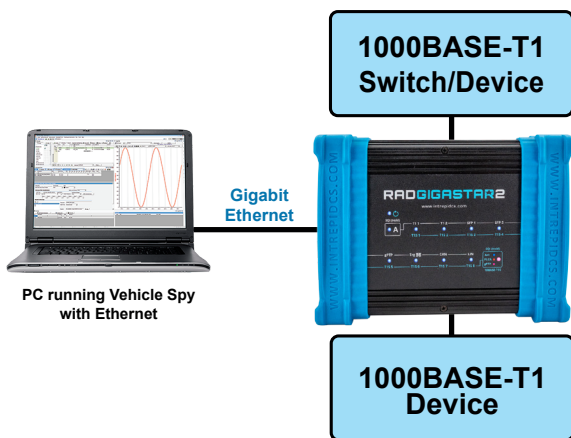

Using the RAD-Gigastar 2 as an active tap

to its partner, ensuring seamless operation of the network. Copies of all messages/streams are also aggregated with precision time stamps and sent to a host PC running Vehicle SPY or Wireshark. This data can also be logged internally, or streamed to an external logging device.

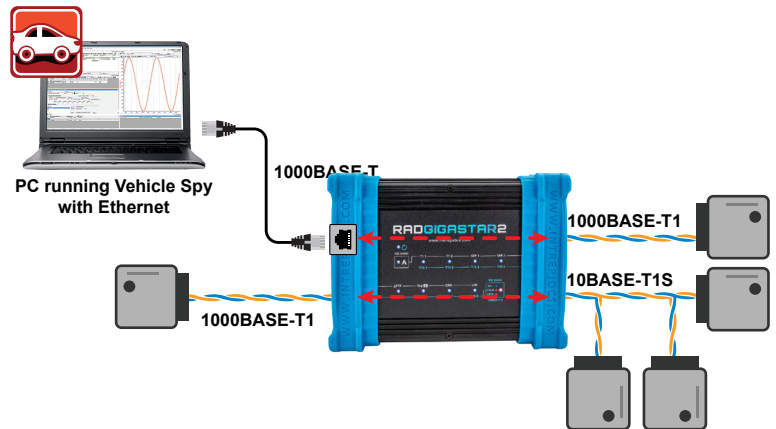

RAD-Gigastar 2 as a dual media converter

Stand-Alone Operation Featuring Real-Time Scripting, Data Logging, and High-Performance Gateways

The RAD-GigaStar 2 is capable of running real-time scripts as a stand-alone device for ECU simulation. This same scripting engine enables high performance gateways between any of its networks.

The RAD-Gigastar2 can also be used as a stand-alone logger using its internal NVM storage and battery backed RTC (Real-Time Clock). Its gPTP synchronization enables it to be integrated into autonomous logger systems consisting of multiple logging devices.

Automotive Ethernet PHY Testing

The RAD-Gigastar 2 provides low level register access to all of its Ethernet PHYs with the use of Vehicle Spy or Intrepid's Open Source API. This is useful for obtaining status and information needed in debugging and testing.

Media Converter Mode

The RAD-GigaStar 2 can act as a media converter between any two of its Ethernet ports. This allows a PC to interact with a 100/1000BASE-T1 or 10BASE-T1S to simulate nodes, perform direct diagnostics, or ECU flashing. This mode can also enable the connection of a 100/1000BASE-T device to an automotive device having 100/1000BASE-T1 or 10BASE-T1S ports, as well as bridge between 100/1000BASE-T1 and 10BASE-T1S devices.

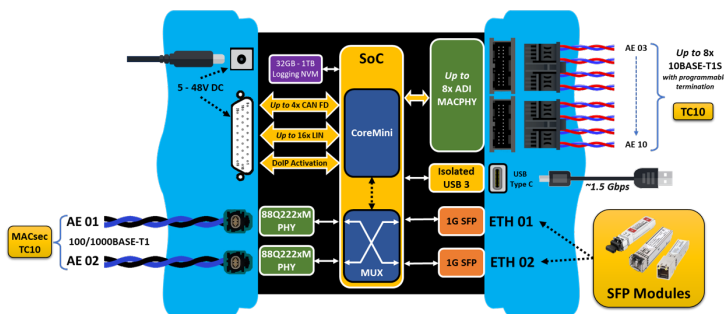

Active Tap Configuration

One use of the RAD-Gigastar 2 is to act as an active tap between 2 ECUs or between an ECU and Ethernet Switch. Up to 2 taps can be created by pairing up any 2 of its Ethernet ports for connection between two devices. The traffic from each device on a tapped link is forwarded

RAD-Gigastar 2

Network Interfaces:

- 2 x 100/1000BASE-T1 Ports
 - Marvell 88Q222xM PHY
 - OPEN Alliance TC10 Sleep and Wakeup
 - Automotive MACsec Capable (TC17)
- 2 x 1G SFP Ports
- Up to 8 x 10BASE-T1S Ports*
 - ADI MACPHY (AD330X)
 - OPEN Alliance TC10 Sleep and Wakeup
 - Software selectable on-board termination (End Node)
- Up to 16 x LIN Interfaces*
- Up to 4 x ISO CAN FD channels with selectable on-board termination*.
- 1 DoIP Activation Line

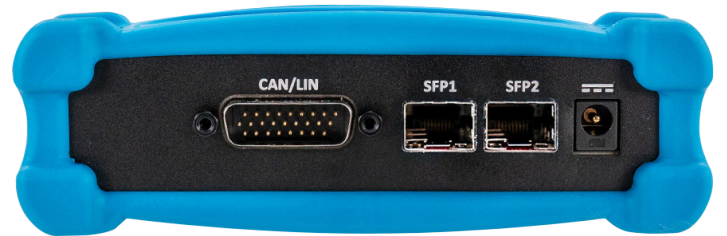
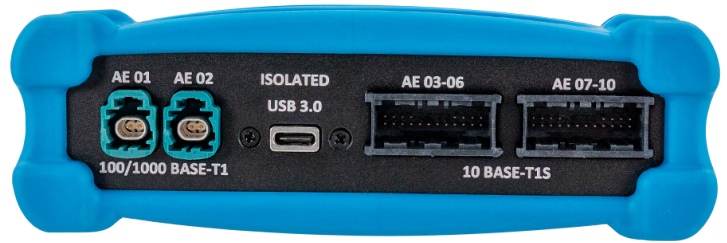

Port Type	Max T1S/CAN Config	Max LIN Config
10BASE-T1S	8	6
CAN / CAN FD	4	1
LIN	6	16
SFPs	2	2
100/1000BASE-T1	2	2

Ordering Information



Part Number	Description
RAD-Gigastar-2	Active Tap / Gateway / Media Converter / Vehicle Interface, & Data Logger

Specifications subject to change; please contact Intrepid for the latest information. All trademarks are the property of their respective owners.

* The RAD-Gigastar 2 offers two configurations. One maximizing the number of LIN interfaces available, and the other maximizing the number of 10BASE-T1S and CAN FD ports available.

Rev. 20260107

Distributor: **NeoMore** 5 Rue de la Plaine 78860 Saint-Nom-la-Bretèche FRANCE +33 1 30 64 15 81 www.neomore.com



INTREPID
CONTROL SYSTEMS
www.intrepidcs.com

1850 Research Drive
Troy, MI 48083 USA
Ph: +1 (586) 731-7950